

CAPACITOR-BASED BUFFER MODULES

- Built-in Capacitors as Energy Source (EDLC Electrochemical Double Layer Capacitors)
- Wide Temperature Range from -40°C to +60°C
- Typically >10 Years Operational Lifetime Expectancy
- Regulated Output Voltage in Buffer Mode
- No Ventilated Cabinets Required (No Generation of Hydrogen as VRLA batteries do)
- Active Balancing for Longest Life and Buffer Times
- Short Charging Time, Unit is Rapidly Back in Ready Mode
- Output is Decoupled from the Input to Separate Load Circuits into Buffered and Non-buffered Sections
- 3 Year Warranty

GENERAL DESCRIPTION

The DIMENSION UC-Series are buffer modules utilizing Electrochemical Double Layer Capacitors (EDLC), commonly known as Ultracapacitors or Supercapacitors, which are installed inside the buffer module. They can bridge power failures or voltage fluctuations and supply voltage to the DC 24V bus for a certain period, which allows for a safe shut-down of the system. Expensive downtimes, long restart cycles and loss of data can be avoided.

In times when the power supply provides sufficient voltages, the buffer module stores energy in the capacitors. In case of a mains voltage fault, this energy is released to the DC bus in a regulated process.

The buffer modules are maintenance-free and have a similar lifetime expectancy as power supplies. No regular replacement of the capacitors is necessary as is required for battery based UPS systems. The wide temperature range from -40°C to +60°C makes the unit suitable for many applications.

The buffer modules come in two versions which differ in the size of the installed capacitors.

SHORT-FORM DATA

Nominal voltage	DC 24-28V	
Output current	15A	continuous
Buffer voltage	22.0 - 22.65V	fixed, 15A – 0A
Input current	typ. 1.1A	during charging, output current not included
Capacitor size	6kWs	UC10.241
	12kWs	UC10.242
Charging time	16 minutes	UC10.241
	32 minutes	UC10.242
Buffer time	16.5s at 10A	UC10.241
	33s at 10A	UC10.242
Power losses	5.5W	in normal mode at 10A output current
Temperature range	-40°C to +60°C operational	
Dimensions W x H x D	126x124x117mm	UC10.241
	198x124x117mm	UC10.242

ORDER NUMBERS

Buffer Module	UC10.241 UC10.242	6kWs energy source 12kWs energy source
Accessory	ZM2.WALL	Wall-mount bracket

MARKINGS



INDEX

	Page		Page
1. Intended Use	3	17. Safety Features	17
2. Installation Notes	3	18. Approvals	18
3. Input	4	19. Fulfilled Standards.....	18
4. Output	5	20. Physical Dimensions and Weight	19
5. Charging	7	21. Accessories	20
6. Buffer Time.....	8	21.1. ZM2.WALL – Wall-Mounting Bracket.....	20
7. Ready and Buffering Relay Contact	9	22. Application Notes.....	21
8. Inhibit Input.....	9	22.1. External Input Protection.....	21
9. Efficiency and Power Losses.....	10	22.2. Output Circuit Breakers.....	21
10. Reliability and Calculated Lifetime	11	22.3. Parallel Use to Increase Output Current..	22
11. Functional Diagram.....	12	22.4. Parallel Use for Redundancy	22
12. Terminals and Wiring.....	13	22.5. Parallel Use for Longer Buffer Times.....	23
13. Front Side and User Elements.....	14	22.6. Using the Inhibit-Input.....	23
14. EMC.....	15	22.7. What do KJ and KWS mean?	24
15. Environment.....	16	22.8. Troubleshooting	24
16. Protection Features	17		

The information presented in this document is believed to be accurate and reliable and may change without notice. No part of this document may be reproduced or utilized in any form without permission in writing from the publisher.

TERMINOLOGY AND ABBREVIATIONS

Buffer Module	Short term buffer system with DC-In-/Output. Utilizes capacitors as energy source
DC-UPS	Uninterruptible power supply system with DC-In-/Output. Utilizes batteries as energy source
Normal mode	Describes a condition where the capacitor is charged, the input voltage is in range and the output is loaded within the allowed limits.
Buffer mode	Describes a condition where the input voltage is below the transfer threshold level, the unit is running on capacitor (buffering) and the output is loaded within the allowed limits.
Charging mode	Describes a condition where the capacitor is being charged, the input voltage is in range and the output is loaded within the allowed limits.
Inhibit mode	Describes a condition where buffering is disabled on purpose (e.g. for service actions)
T.b.d.	To be defined, value or description will follow later.
AC 24V	A figure displayed with the AC or DC before the value represents a nominal voltage with standard tolerances included. E.g.: DC 12V describes a 12V battery disregarding whether it is full (13.7V) or flat (10V)
24Vac	A figure with the unit (Vac) at the end is a momentary figure without any additional tolerances included.
may	A key word indicating flexibility of choice with no implied preference.
shall	A key word indicating a mandatory requirement.
should	A key word indicating flexibility of choice with a strongly preferred implementation.

1. INTENDED USE

This device is designed for installation in an enclosure, use an appropriate enclosure which protects against mechanical, electrical and fire hazards.

This device is intended for professional use in areas such as in industrial control, office, communication, and instrumentation equipment.

Do not use this device in equipment or systems where malfunction may cause severe personal injury or threaten human life.

2. INSTALLATION NOTES

This device may only be installed and put into operation by qualified personnel.

This device does not contain serviceable parts. The tripping of an internal fuse is caused by an internal defect. If damage or malfunction should occur during installation or operation, immediately turn power off and send unit to the factory for inspection.

Mount the unit on a DIN-rail so that the power terminals are located on the top of the unit.

This device is designed for convection cooling and does not require an external fan. Do not obstruct airflow and do not cover ventilation grid (e.g. cable conduits) by more than 15%!

Keep the following installation clearances:

40mm on top,

20mm on the bottom,

5mm on the left and right sides are recommended when the device is loaded permanently with more than 50% of the rated power. Increase this clearance to 15mm in case the adjacent device is a heat source (e.g. a power supply).

Fig. 2-1 **Typical wiring diagram**

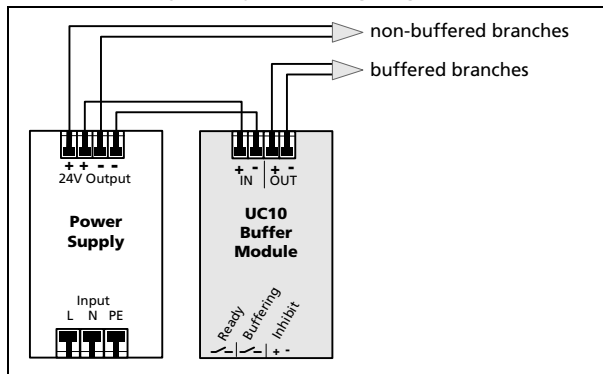

The EDLC (storage capacitors) contain Acetonitrile and Tetraethylammonium-tetrafluoroborate. These components are declared as non-dangerous goods in regards to shipment. A safety datasheet can be provided when required.

⚠ WARNING Risk of electrical shock, fire, personal injury or death.

- Turn power off before working on the device. Protect against inadvertent re-powering.
- Make sure that the wiring is correct by following all local and national codes.
- Do not modify or repair the unit.
- Do not open the unit as dangerous voltages may be present inside.
- Do not open the unit as hazardous energy may be present inside.

Info for service personnel: Before opening the unit wait at least 45 minutes after disconnecting the unit from input power so that the remaining capacitor charge has completely been discharged.

- Use caution to prevent any foreign objects from entering the housing.
- Do not use in wet locations or in areas where moisture or condensation can be expected.
- Do not touch during power-on, and immediately after power-off. Hot surfaces may cause burns.

3. INPUT

Input voltage	nom.	DC 24-28V	
Input voltage ranges	typ. max.	22.5 to 30Vdc 30 to 35Vdc	continuous operation temporarily allowed, no damage to the unit Between 30 and 35Vdc buffering is not possible, the unit indicates "Check Input Voltage" with the red LED on the front
Transfer threshold voltage	typ. typ. max.	22.45V $\pm 1\%$ 22.55V 22.60V 22.88V	at no load at 10A buffer current at 15A buffer current at 15A buffer current The transfer threshold voltage describes the input voltage, where the unit switches into buffer mode and delivers output voltage from the capacitors if the input was above the turn-on level before and all other buffer conditions are fulfilled.
Turn-on voltage	typ. max.	22.8Vdc 23.0V	The output does not switch on if the input voltage is below this level.
Allowed voltage between input and earth (chassis)	max.	60Vdc or 42.4Vac	continuous, IEC 62103
Current consumption	typ. typ. max.	0.09A 1.1A 1.3A	capacitors charged, output current not included during charging, output current not included
Input current	max.	17A	during charging an full output current
Return current	typ. max.	-9mA -11mA	Leakage current to input in buffer mode
Suitable power sources on input		no limitation in the maximum power supply current	

Fig. 3-1 Input voltage range

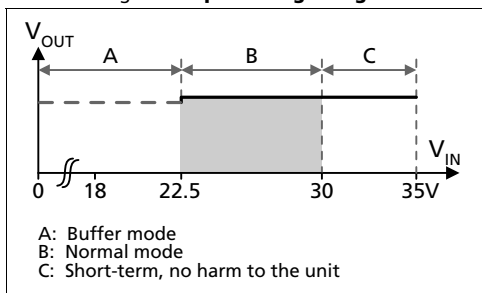
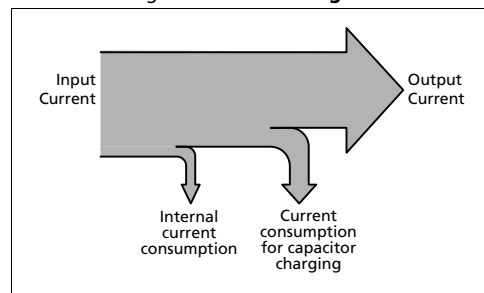

Fig. 3-2 Current budget



4. OUTPUT

The output section of the buffer module is fully controlled and is equipped with an electronic current limitation. A current overloading of the buffer module cannot happen, independent of which sizes of power supplies are used on the input of the buffer module.

The current limitation works in a switching mode which reduces the power losses and heat generation to a minimum.

Output in normal mode:

In normal mode (and also in charging mode), the output voltage is slightly lower as the input voltage. The output voltage follows the input voltage reduced by the input to output voltage drop.

Input to output voltage drop	max.	0.3V 0.45V	at 10A output current at 15A output current, see Fig. 4-1
Ripple & noise voltage	max.	20mVpp	at 20Hz to 20MHz, 50Ohm measurement. This figure indicates the ripple & noise voltage which is produced by the buffer module. It can be higher if the supplying source has a higher ripple and noise voltage.
Output current	nom.	15A	continuously allowed for the entire voltage range
Output power	nom.	360W	at 24V
Overload behavior		continuous current	see Fig. 4-2
Current limitation	typ. min.	16A 15A	see Fig. 4-2
Short-circuit current	min. max.	17.9A 21.0A	load impedance 100mOhm, see Fig. 4-2 load impedance 100mOhm, see Fig. 4-2
Output capacitance	typ.	1 500µF	included inside the buffer module
Capacitive and inductive loads		No limitation	

Output in buffer mode:

The output voltage is fully regulated in buffer mode.

The unit switches into buffer mode, when the input voltage falls below the transfer threshold input voltage level, The buffer voltage is slightly lower than this threshold input voltage. The unit switches back to normal mode, as soon as the input voltage exceeds the transfer threshold voltage, which is specified in the input section.

Output voltage	typ.	22.45V $\pm 1\%$ 22.25V $\pm 1\%$ 22.12V $\pm 1\%$	at no load at 10A buffer current at 15A buffer current
Ripple & noise voltage	max.	20mVpp	at 20Hz to 20MHz, 50Ohm measurement
Output current	nom.	15A	continuously allowed
Output power	nom.	360W	at 24V
Overload behavior		continuous current	see Fig. 4-2
Current limitation	typ. min.	16A 15A	see Fig. 4-2
Short-circuit current	min. max.	17.9A 21.0A	load impedance 70mOhm, see Fig. 4-2 load impedance 50mOhm, see Fig. 4-2
Capacitive and inductive loads		No limitation	

Fig. 4-1 **Input to output voltage drop in normal mode, typ.**

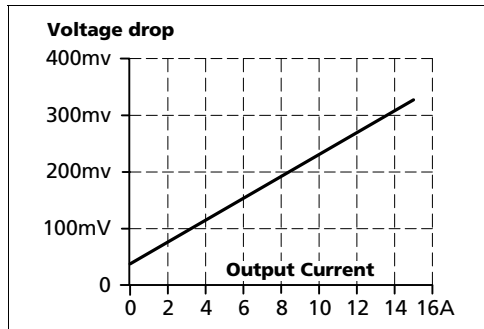

Fig. 4-2 **Output characteristic and overload behavior in normal and buffer mode, typ.**

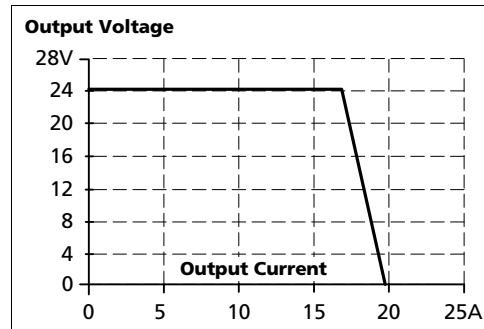

Fig. 4-3 **Transition from buffer mode to normal mode and vice versa, definitions**

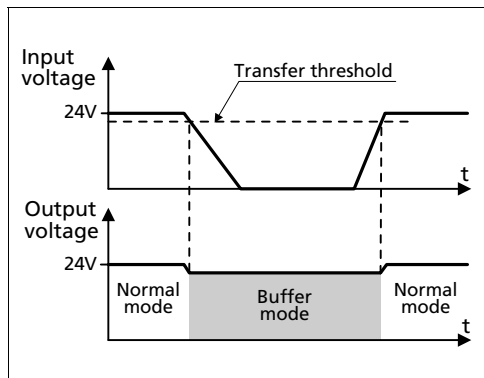
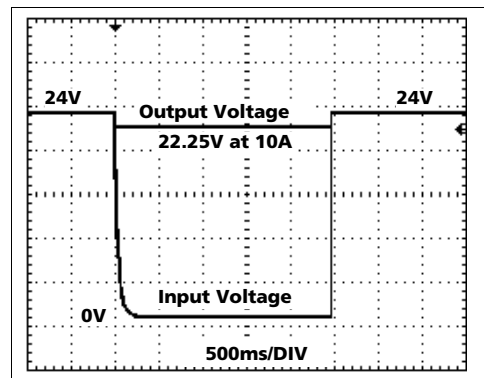

Fig. 4-4 **Transfer behavior, typ.**



5. CHARGING

During charging, the buffer module consumes additional current from the input. See chapter "Input".
When charging is completed, the "Ready LED" stops flashing and is on solid and the "Ready relay contact" closes.

		UC10.241	UC10.242	
Charging time initial charging ^{*)}	typ.	16 minutes	32 minutes	when capacitor is completely discharged
Charging time recharging ^{**)}	typ.	1 minute 50s	1 minute 50s	after discharging with 10A for 10s
	typ.	3 minutes 50s	7 minutes 40s	after discharging with 10A until buffering stops
	typ.	4 minutes 40s	9 minutes 40s	after discharging with 5A until buffering stops
	typ.	5 minutes 40s	11 minutes 15s	after discharging with 1A until buffering stops
Allowed number of charging / discharging cycles		no limitation	no limitation	

*) Initial charging means that no input voltage was applied for several hours or longer and the capacitor is completely discharged by the internal electronics.

***) Recharging means that the electronics inside the buffer module has not completely discharged the capacitor. The values in the table apply when the input voltage is applied immediately after buffering has stopped.

Note:

At the end of the charging process the active balancing circuit reduces the charging current periodically, which can be seen as current oscillations on the input current.

6. BUFFER TIME

The following times are typical values for a new product and the aging effect during operation is not included. More information about the reduction of the buffer time over the life of the product can be found in the chapter "reliability".

		UC10.241	UC10.242	
Buffer Time	typ.	340s	680s	at 0.5A buffer current
	typ.	200s	400s	at 1A buffer current
	typ.	68s	136s	at 3A buffer current
	typ.	39s	78s	at 5A buffer current
	typ.	26s	53s	at 7A buffer current
	typ.	16.5s	33s	at 10A buffer current
	typ.	9s	18s	at 15A buffer current

Fig. 6-1 Buffer time vs. buffer current, typ.

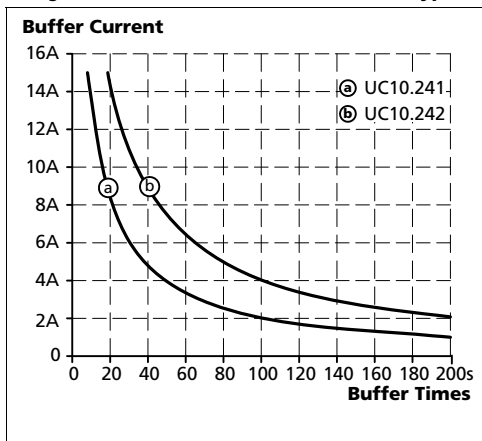

7. READY AND BUFFERING RELAY CONTACT

The buffer modules are equipped with two independent relay contacts for remote monitoring and controlling of the unit.

Ready contact

Contact is closed when capacitor is completely charged, input voltage is sufficient and inhibit signal is not active.

Contact ratings	max.	60Vdc 0.3A, 30Vdc 1A, 30Vac 0.5A	resistive load
	min.	1mA at 5Vdc	min. permissible load
Isolation voltage	500Vac, signal port to power port		

Buffering contact

Contact is closed when unit is buffering.

Contact ratings	max.	60Vdc 0.3A, 30Vdc 1A, 30Vac 0.5A	resistive load
	min.	1mA at 5Vdc	min. permissible load
Isolation voltage	500Vac, signal port to power port		

8. INHIBIT INPUT

The inhibit input disables buffering. In normal mode, a static signal is required. In buffer mode, a pulse with a minimum length of 250ms is required to stop buffering. The inhibit is stored and can be reset by cycling the input voltage. See also section 22.6 for application notes.

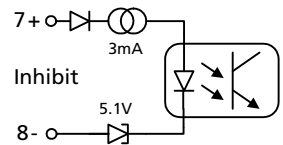

Signal voltage	max.	35Vdc
Signal current	max.	6mA, current limited
Inhibit threshold	min.	6Vdc, buffering is disabled above this threshold level
	max.	10Vdc
Isolation voltage	500Vac, signal port to power port	

9. EFFICIENCY AND POWER LOSSES

Efficiency	typ.	97.8%	Normal mode, 10A output current, capacitor fully charged
	typ.	97.8%	Normal mode, 15A output current, capacitor fully charged
Power losses	typ.	2.9W	Normal mode, 0A output current, capacitor fully charged
	typ.	5.5W	Normal mode, 10A output current, capacitor fully charged
	typ.	7.7W	Normal mode, 15A output current, capacitor fully charged
	typ.	5.0W	During charging, 0A output current

Fig. 9-1 Efficiency vs. output current in normal mode, typ.

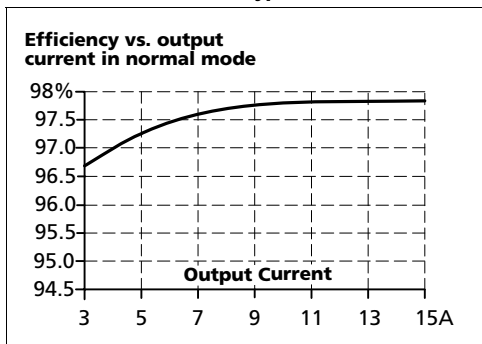
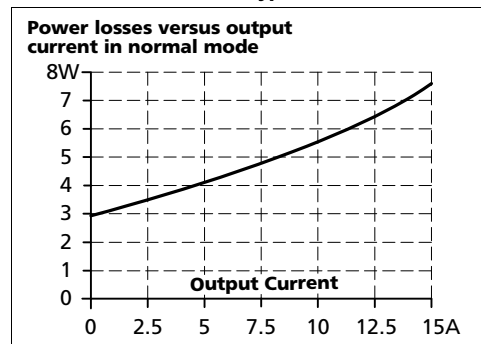

Fig. 9-2 Power losses vs. output current in normal mode, typ.



10. RELIABILITY AND CALCULATED LIFETIME

The lifetime expectancy of the ultracapacitor buffer module is predominantly affected by the storage capacitors. The biggest influence in lifetime is a combination of operating voltage and operating temperature of these capacitors. To gain longest lifetimes, PULS does not utilize the full allowed working voltage for these capacitors and therefore accepts a slightly shorter buffer time.

The ultracapacitors have an almost unlimited shelf life (unlike batteries) when stored uncharged at 25°C.

The ultracapacitors do not experience a true end-of-life, rather the capacitance continually degrades over the life of the buffer module. The typical degradation behavior resembles that of an exponential decay. The majority of the capacitance reduction occurs during the initial use of the buffer module and this change in performance then levels off over time.

When working with the specified lifetime numbers, the remaining capacity must always be taken into account. The capacity correlates linearly to the buffer time.

The number of charge/ discharge cycles does not have an impact on the lifetime as long as the number of cycles does not exceed 100 000. This should not be the case for a typical backup operation.

Fig. 10-1 Lifetime expectancy vs. ambient temperature

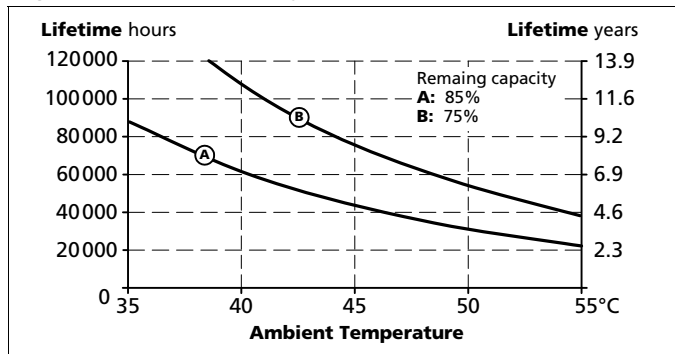

Remaining capacity	85%	75%	
Lifetime expectancy *)	>105 000h (>12 years)	>105 000h (>12 years)	at 25°C ambient temperature
	62 000h (7.2 years)	>105 000h (>12 years)	at 40°C ambient temperature
	22 000h (2.5 years)	38 000h (4.4 years)	at 55°C ambient temperature
MTBF	UC10.241	UC10.242	
MTBF **) SN 29500, IEC 61709	T.B.D.	T.B.D.	at 24V and 40°C
	T.B.D.	T.B.D.	at 24V and 25°C
MTBF **) MIL HDBK 217F	T.B.D.	T.B.D.	at 24V and 40°C; Ground Benign GB40
	T.B.D.	T.B.D.	at 24V and 25°C; Ground Benign GB25

*) The **Lifetime expectancy** shown in the table indicates the minimum operating hours (service life) and is determined by the lifetime expectancy of the built-in electrolytic capacitors and storage capacitors (ultracapacitors). Lifetime expectancy is specified in operational hours and is calculated according to the capacitor's manufacturer specification.

) **MTBF stands for **Mean Time Between Failure**, which is calculated according to statistical device failures, and indicates reliability of a device. It is the statistical representation of the likelihood of a unit to fail and does not necessarily represent the life of a product. The MTBF figure is a statistical representation of the likelihood of a device to fail. A MTBF figure of e.g. 1 000 000h means that statistically one unit will fail every 100 hours if 10 000 units are installed in the field. However, it can not be determined if the failed unit has been running for 50 000h or only for 100h.

11. FUNCTIONAL DIAGRAM

Fig. 11-1 Functional diagram

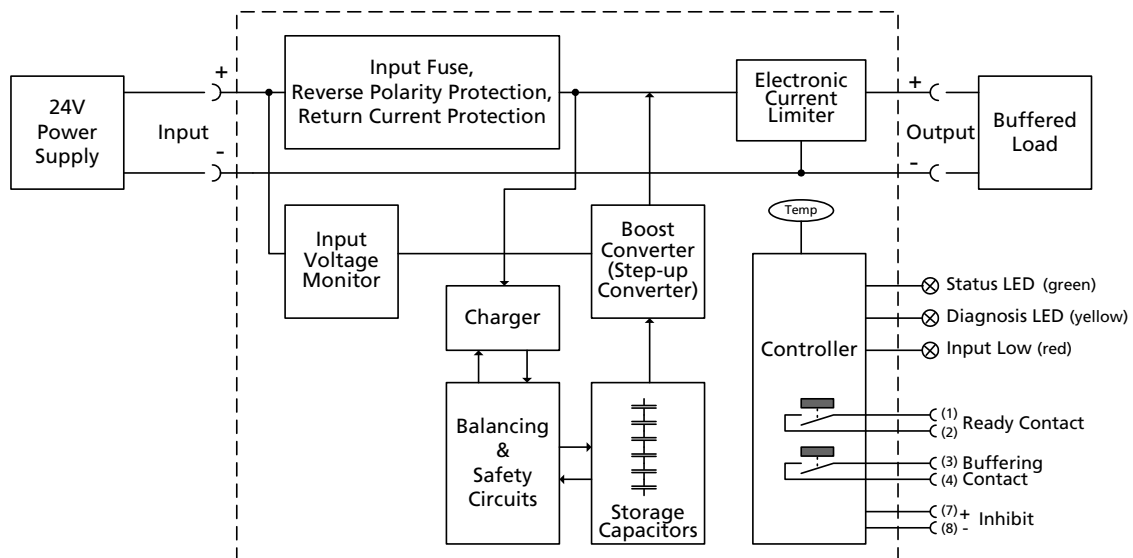

12. TERMINALS AND WIRING

The terminals are IP20 Finger safe constructed and suitable for field and factory wiring.

Type	Input and output	Signals
	bi-stable quick-connect spring-clamp terminals	pluggable screw terminals
Solid wire	0.5-6mm ²	0.2-1.5mm ²
Stranded wire	0.5-4mm ²	0.2-1.5mm ²
American Wire Gauge	AWG 20-10	AWG 22-14
Max. wire diameter	2.8mm (including ferrules)	1.5mm (including ferrules)
Wire stripping length	10mm / 0.4inch	6mm / 0.24inch
Screwdriver	-	3mm slotted
Recommended tightening torque	not applicable	0.4Nm. 3.5lb.in

Instructions:

- a) Use appropriate copper cables that are designed for minimum operating temperatures of:
60°C for ambient up to 45°C and
75°C for ambient up to 60°C minimum
90°C for ambient up to 70°C minimum.
- b) Follow national installation codes and installation regulations!
- c) Ensure that all strands of a stranded wire enter the terminal connection!
- d) Unused terminal compartments should be securely tightened or closed.
- e) Ferrules are allowed.

Fig. 12-1 Connecting a wire

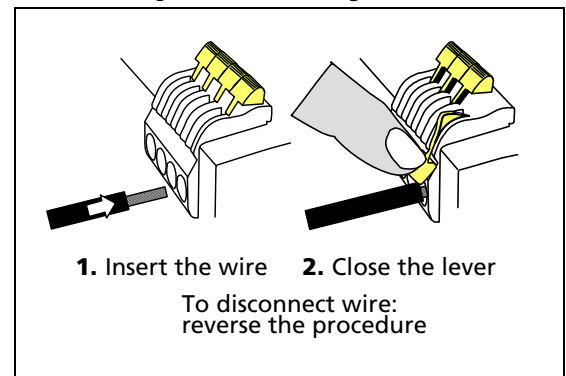

13. FRONT SIDE AND USER ELEMENTS

Fig. 13-1 Front side (UC10.241)

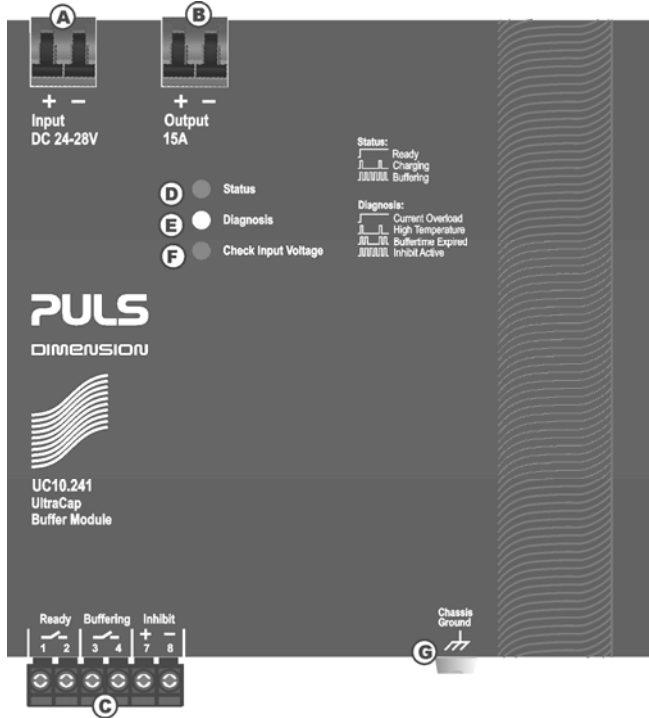

A Input Terminals

(quick-connect spring-clamp terminals)

B Output Terminals

(quick-connect spring-clamp terminals)

The minus-pole has the same reference as the minus-pole of the input terminals

C Signal connector (plug connector)

- Ready:

contact is closed when status LED indicates ready

- Buffering:

contact is closed during buffering

- Inhibit:

a voltage applied on this input signal disables buffering (e.g. during service)

D Status LED (green)

- Ready:

capacitor is fully charged, no failures detected

- Charging: capacitor being charged

- Buffering: capacitor being discharged

Flashing pattern for the green status LED:

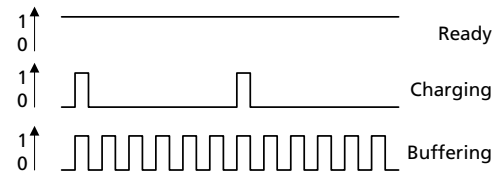

E Diagnosis LED (yellow)

Helps troubleshooting and indicates the following:

- Current Overload:

output voltage below 20Vdc due to a too high output current, ready contact opens

- High Temperature:

signal for too high capacitor temperature (>65°C), charging and buffering is still possible, ready contact opens

- Buffer Time Expired:

buffering stopped due to discharged capacitors

- Inhibit Active:

buffering is blocked by the inhibit signal

Flashing pattern for the yellow diagnosis LED:

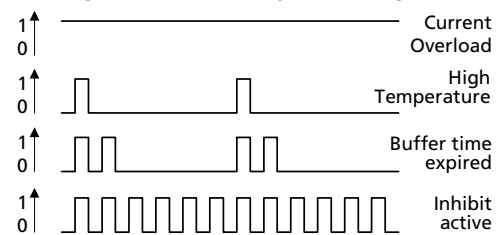

E "Check Input Voltage" LED (red)

Indicates a too low input voltage.

The input voltage must be at least 23V to turn-on the output and to start charging of the capacitors.

G Chassis ground (screw)

Use a M4 ring-type terminal to connect the housing to ground, when required

14. EMC

The buffer module is suitable for applications in industrial environment as well as in residential, commercial and light industry environment without any restrictions. A detailed EMC report is available on request.

EMC Immunity	According generic standards: EN 61000-6-1 and EN 61000-6-2			
Electrostatic discharge	EN 61000-4-2	contact discharge *) air discharge *)	8kV 15kV	Criterion A Criterion A
Electromagnetic RF field	EN 61000-4-3	80MHz-2.7GHz	10V/m	Criterion A
Fast transients (Burst)	EN 61000-4-4	input lines output lines signals **)	2kV 2kV 2kV	Criterion A Criterion A Criterion A
Surge voltage on input	EN 61000-4-5	+ → - + / - → chassis ground	500V 500V	Criterion A Criterion A
Surge voltage on output	EN 61000-4-5	+ → - + / - → chassis ground	500V 500V	Criterion A Criterion A
Surge voltage on inhibit input and relay outputs	EN 61000-4-5	opposite polarity of signals signals → chassis ground	500V 500V	Criterion A Criterion A
Conducted disturbance	EN 61000-4-6	0.15-80MHz	10V	Criterion A

*) Chassis ground connection earthed (grounded)

**) Tested with coupling clamp

Criteria:

A: Buffer module shows normal operation behavior within the defined limits.

EMC Emission	According generic standards: EN 61000-6-3 and EN 61000-6-4		
Conducted emission***)	EN 55022	input lines	Class B
	EN 55022	output lines	Class B
Radiated emission	EN 55011, EN 55022		Class B

This device complies with FCC Part 15 rules.

Operation is subjected to following two conditions: (1) this device may not cause harmful interference, and (2) this device must accept any interference received, including interference that may cause undesired operation.

***) measured with voltage probe

Switching Frequencies	The unit has two converters with two different switching frequencies and one switch-mode current limiter included.	
Switching frequency 1	100kHz	Boost Converter (active only in buffer mode)
Switching frequency 2	78kHz	Electronic output current limitation
Switching frequency 3	19.5kHz	Charger

15. ENVIRONMENT

Operational temperature *)	-40°C to +60°C (-40°F to 140°F)	
Storage temperature	-40 to +70°C (-40°F to 158°F)	for storage and transportation
Humidity **)	5 to 95% r.H.	IEC 60068-2-30
Vibration sinusoidal	2-17.8Hz: ±1.6mm; 17.8-500Hz: 2g ***) 2 hours / axis	IEC 60068-2-6
Shock	30g 6ms, 20g 11ms ***) 3 bumps / direction, 18 bumps in total	IEC 60068-2-27
Altitude	0 to 6000m (0 to 20 000ft)	Approvals apply only up to 2000m
Over-voltage category	III II	IEC 62103, EN 50178, altitudes up to 2000m altitudes from 2000m to 6000m
Degree of pollution	2	IEC 62103, EN 50178, not conductive
LABS compatibility	The unit does not release any silicone or other LABS-critical substances and is suitable for use in paint shops.	LABS compatibility

*) Operational temperature is the same as the ambient temperature and is defined as the air temperature 2cm below the unit.

***) Do not energize while condensation is present

***) Higher levels allowed when using the wall mounting bracket ZM2.WALL

Fig. 15-1 **Output current vs. ambient temp.**

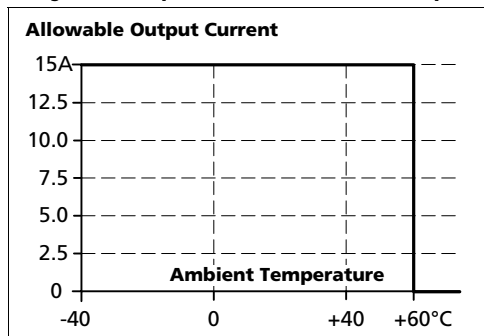

16. PROTECTION FEATURES



Output protection	Electronically protected against overload, no-load and short-circuits *)	
Output over-voltage protection in buffer mode	typ. 32Vdc max. 35Vdc	In case of an internal buffer module defect, a redundant circuit limits the maximum output voltage. The output shuts down and automatically attempts to restart.
Degree of protection	IP 20	EN/IEC 60529
Penetration protection	> 3.5mm	e.g. screws, small parts
Over-temperature protection	included	Output shuts down with automatic restart
Input over-voltage protection	-	Max. 35Vdc, no harm or defect of the unit
Internal input fuse	25A, blade type	Non user replaceable The tripping of this fuse is caused by an internal defect. In such cases, send unit to the factory for inspection.
Overcharging of capacitors	included	The capacitors are permanently monitored. An active balancing circuit ensures uniform capacitor voltages. If necessary, the charging current will be reduced to a safe value.
Failing of one or more capacitor in the capacitor-string	included	Ready contact open, moving light pattern on the three LEDs
Temperature of capacitors	included	Indicated by the diagnosis LED, ready contact open
Internal errors (broken wires, ...)	included	Charging is stopped, ready contact open, moving light pattern on the three LEDs

*) In case of a protection event, audible noise may occur.

17. SAFETY FEATURES

Output voltage	SELV PELV	IEC/EN 60950-1 IEC/EN 60204-1, EN 50178, IEC 62103, IEC 60364-4-41
	Max. allowed voltage between any input, output or signal pin and ground: 60Vdc or 42.4Vac. The input must be powered from a PELV or SELV power source.	
Class of protection	III	PE (Protective Earth) connection not required
Isolation resistance	> 5MΩ	input to output, 500Vdc
Dielectric strength	500Vac 500Vac	Power port to signal port Power port / signal port to housing
Touch current (leakage current)	The leakage current which is produced by the buffer module itself depends on the input voltage ripple and need to be investigated in the final application. For a smooth DC input voltage, the produced leakage current is less than 100µA.	

18. APPROVALS

EC Declaration of Conformity		The CE mark indicates conformance with the - EMC directive 2004/108/EC, - Low-voltage directive (LVD) 2006/95/EC and - RoHS directive 2011/65/EC.
IEC 60950-1 2 nd Edition pending		CB Scheme, Information Technology Equipment
UL 508 pending		Listed for use as Industrial Control Equipment; U.S.A. (UL 508) and Canada (C22.2 No. 107-1-01); E-File: E198865
UL 60950-1 2 nd Edition pending		Recognized for use as Information Technology Equipment, Level 5; U.S.A. (UL 60950-1) and Canada (C22.2 No. 60950-1); E-File: E137006
GOST P, pending		Certificate of Conformity for Russia and other GUS countries

19. FULFILLED STANDARDS

EN/IEC 60204-1, pending	Safety of Electrical Equipment of Machines
EN/IEC 61131-2, pending	Programmable Controllers
EN 50178, IEC 62103, pending	Electronic Equipment in Power Installations

20. PHYSICAL DIMENSIONS AND WEIGHT

Weight	UC10.241: 1150g / 2.54lb UC10.242: 1720g / 3.79lb
DIN-Rail	Use 35mm DIN-rails according to EN 60715 or EN 50022 with a height of 7.5 or 15mm. The DIN-rail height must be added to the unit depth (127mm) to calculate the total required installation depth.
Installation Clearances	See chapter 2.

Fig. 20-1 **Front view UC10.241**

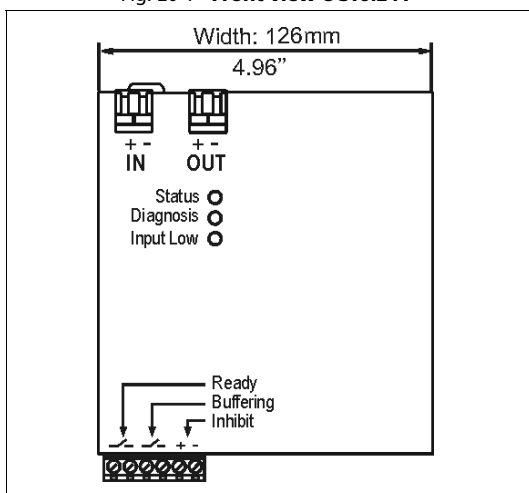

Fig. 20-2 **Front view UC10.242**

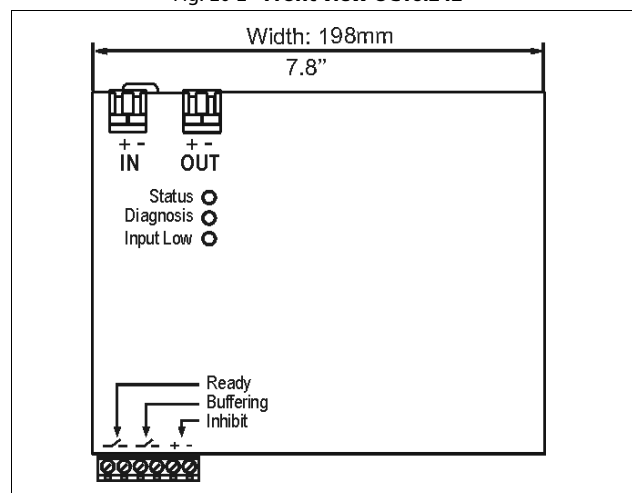
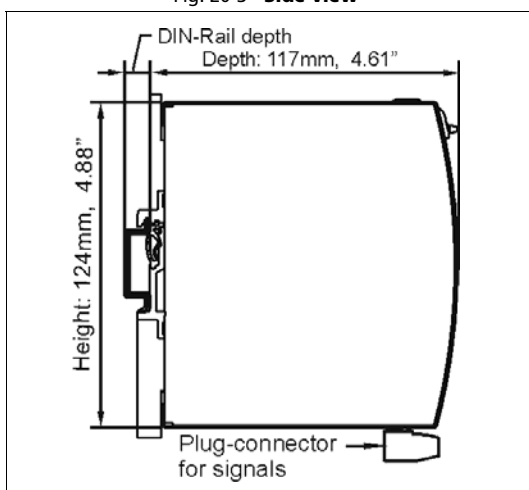

Fig. 20-3 **Side view**



21. ACCESSORIES

21.1. ZM2.WALL – WALL-MOUNTING BRACKET

This bracket is used to mount the buffer module onto a flat surface without utilizing a DIN-Rail.

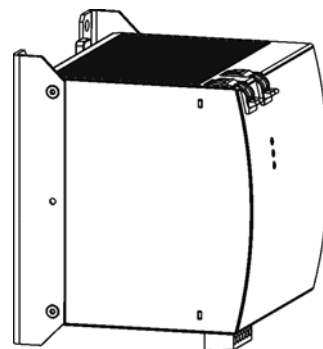
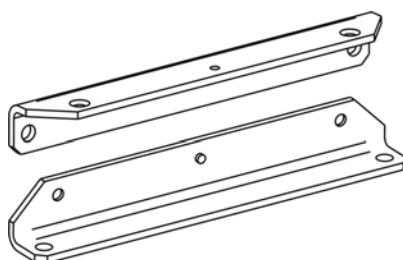

22. APPLICATION NOTES

22.1. EXTERNAL INPUT PROTECTION

The buffer module is tested and approved for branch circuits up to 50A. An external protection is only required, if the supplying branch has an ampacity greater than this. If an external fuse is necessary or utilized, minimum requirements need to be considered to avoid nuisance tripping of the circuit breaker. A minimum value of 20A B- or C-Characteristic breaker should be used.

Check also local codes and local requirements. In some countries local regulations might apply.

22.2. OUTPUT CIRCUIT BREAKERS

The output of the buffer module is equipped with an electronic current limitation. An overload or short-circuit on the output is electronically protected and cannot cause any harms, independent of which sizes of power supplies are used on the input of the buffer module.

However, some applications require branch circuit or branch circuit conductor protection. Therefore standard miniature circuit breakers (MCB's or UL 1077 circuit breakers) are commonly used on 24V branches.

MCB's are designed to protect wires and circuits. If the ampere value and the characteristics of the MCB are adapted to the wire size that is used, the wiring is considered as thermally safe regardless of whether the MCB opens or not.

To avoid voltage dips and under-voltage situations in adjacent 24V branches which are supplied by the same source, a fast (magnetic) tripping of the MCB is desired. A quick shutdown within 10ms is necessary corresponding roughly to the ride-through time of PLC's. This requires high peak currents to open the circuit breaker in the required time. Furthermore, the impedance of the faulty branch must be sufficiently small in order for the current to actually flow. The following table has typical test results showing which B- and C-Characteristic MCBs magnetically trip depending on the wire cross section and wire length.

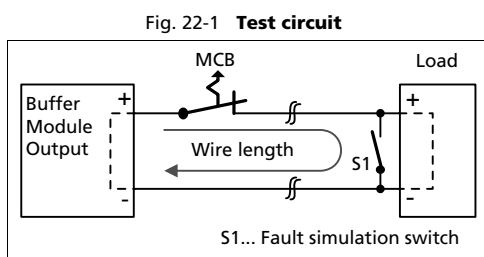

Maximal wire length*) for a fast (magnetic) tripping:

	0.75mm ²	1.0mm ²	1.5mm ²	2.5mm ²
C-2A	20m	25m	39m	58m
C-3A	12m	14m	24m	39m
C-4A	3m	3m	4m	4m

*) Don't forget to consider twice the distance to the load (or cable length) when calculating the total wire length (+ and - wire).

22.3. PARALLEL USE TO INCREASE OUTPUT CURRENT

Do not use the buffer modules in parallel to increase the output power.

22.4. PARALLEL USE FOR REDUNDANCY

Two buffer modules can be paralleled to build a 1+1 redundant system to gain higher system reliability.

Recommendations for building redundant power systems:

- Use separate input fuses for each power supply.
- Set the power supply into "Parallel use" mode if available.
- Use a redundancy module to decouple the two power sources.
- Monitor the individual sources. Therefore, use the alarm contacts of the YRM2.DIODE redundancy module. (The YRM2.DIODE is suitable for a 10A redundant system)
- It is desirable to set the output voltages of all power supplies to the same value ($\pm 100\text{mV}$) or leave it at the factory setting.

Fig. 22-2 **Wiring example for a fully redundant system, redundant power supplies and redundant buffer modules**

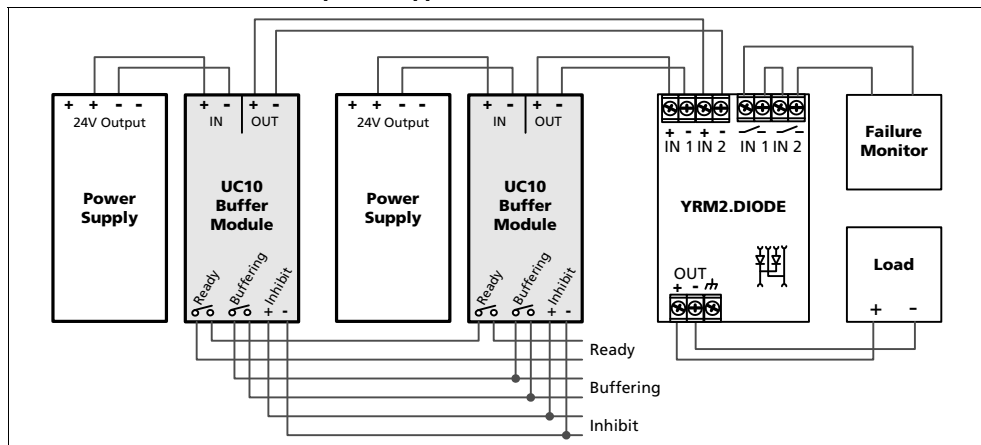

22.5. PARALLEL USE FOR LONGER BUFFER TIMES

Buffer modules can be paralleled to extend the buffer time.

Fig. 22-3 **Wiring example for parallel use for longer buffer times**

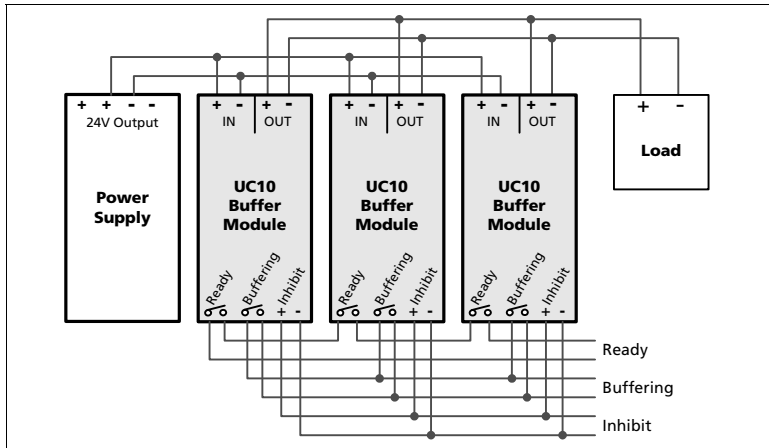

22.6. USING THE INHIBIT-INPUT

The inhibit-input disables buffering. In normal mode, a static signal is required. In buffer mode, a pulse with a minimum length of 250ms is required to stop buffering. The inhibit signal is stored and can be reset by cycling the input voltage.

For service purposes, the inhibit input can also be used to connect a service switch. Therefore, the inhibit signal can be supplied from the output of the buffer module.

Fig. 22-4 **Wiring example for inhibit input**

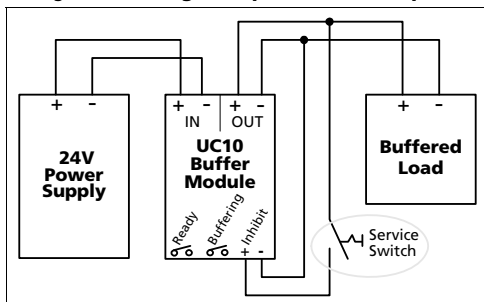

22.7. WHAT DO KJ AND KWS MEAN?

The units kJ (kilo Joule) or kW (kilo Watt seconds) is used for specifying the installed storage capacitor size.

1 kJ = 1 kW = 1000Ws

The stored energy of a capacitor can be calculated with the following formula:

$$Energy(Ws) = \frac{C * U^2}{2}$$

For example: A 350F (Farad) capacitor which is charged to 2.5V has the following energy

$$E = \frac{350F * 2.5V^2}{2} = 1093Ws = 1.09kWs$$

During discharging of the capacitor, the voltage decreases with the amount of discharge. A boost converter is needed to generate a stable output voltage. The boost converter needs a minimum input voltage (cut-off voltage), which reduces the amount of energy. The cut-off voltage usually depends on the load current, the lower the load current, the lower the cut-off voltage.

Considering this voltage range, the energy can be calculated with the following formula (full charge voltage= U1= 2.5V, cut-off voltage= U2= 1V):

$$E = \frac{C * (U1^2 - U2^2)}{2} = \frac{350 * (2.5^2 - 1^2)}{2} = 919Ws = 0.92kWs$$

The energy which can be used for the 24V loads is further reduced by the efficiency of the boost converter.

The UC10.241 has a rated capacitor size of 6kWs and the UC10.242 12kWs. This is the energy which can be used for 24V load at low load currents.

Calculation of the needed energy:

Example: A power of 45W is needed for 2 minutes:

$$E = P * t = 45 W * 120 s = 5400 Ws = 5.4 kWs$$

Always check with the buffer time curve (see Fig. 6-1) if the load can be powered for the required period of time!

22.8. TROUBLESHOOTING

The following guidelines provide instructions for fixing the most common failures and problems. Always start with the most likely and easiest to check condition. Some of the suggestions may require special safety precautions. See notes in section 2 first.

Symptom:	Action:
"Check input voltage" LED is on	- Check input voltage (must be between 22.8V and 30V)
Buffer module did not buffer	- Inhibit input was set. - Capacitor did not have enough time to be charged.
Buffer module stopped buffering	- Capacitor was discharged. - Capacitor did not have enough time to be charged. - Inhibit was activated
Output has shut down in normal mode	- Over-temperature protection might have triggered. Let the buffer module cool down.
Buffer module constantly switches between normal mode and buffer mode	The supplying source on the input is too small and can not deliver sufficient current. Use a larger power supply or reduce the output load