

LED ceiling-recessed luminaire

Modular LED ceiling-recessed luminaire with lens optic. Luminaire input power: 17.4 W, with LED converter; LED service life lasts 100000 h before luminous flux is reduced to 80% of the initial value. Chromaticity tolerance (initial MacAdam): 2. Luminaire luminous flux: 2830 lm, Luminaire efficacy: 163 lm/W. Colour rendering $R_a > 80$, colour temperature 4000 K. Symmetric very wide distribution luminaire (wide beam). Light control via square lens optic for glare-free light distribution with $UGR < 19$ and $L65 < 3000 \text{ cd/m}^2$ as per EN 12464; low dirt sensitivity and simple cleaning; flat sheet steel luminaire housing with enamelled finish in white; Installation as height-adjustable luminaire for cut ceiling apertures and modular ceilings with concealed or visible grid system;

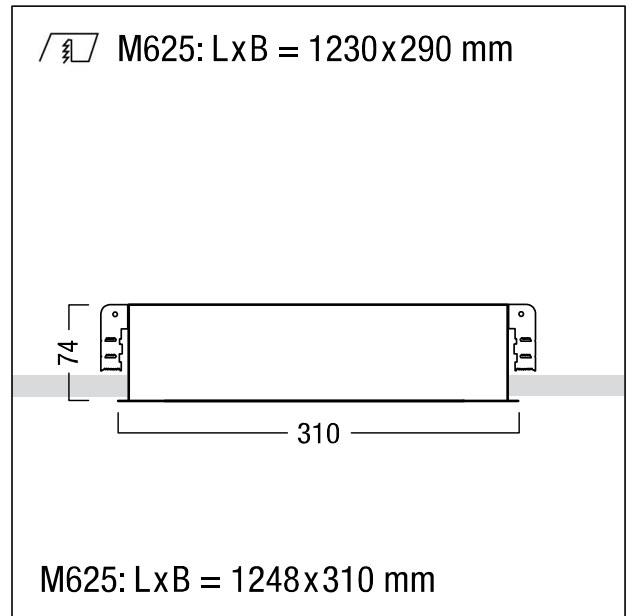

ZS_MIR_F_Linse_niv_L.jpg



ZS_MEL_M_L_NIV_M625L.wmf

Light Distribution

STD - standard

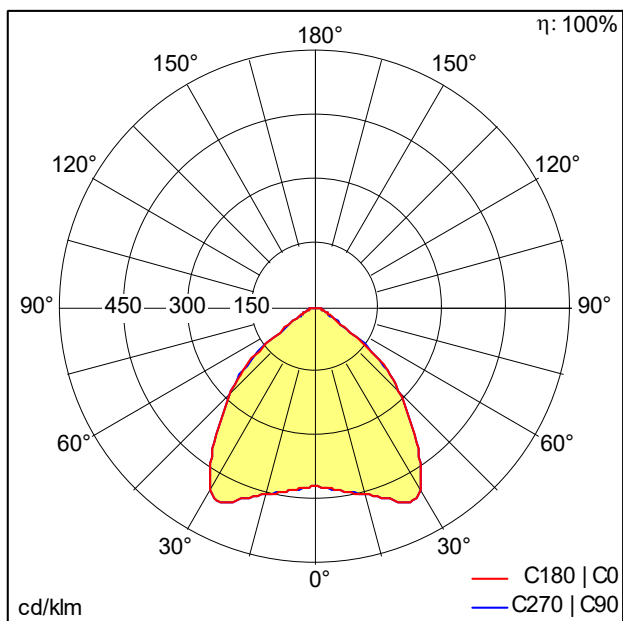

D43022_MIRL_NIV_2800-840_M625L_WB_EVG_WH.Idt

- Light Source: LED
- Luminaire luminous flux*: 2830 lm
- Luminaire efficacy*: 163 lm/W
- Colour Rendering Index min.: 80
- Ballast: 1 x 28000680 LC 50W 100-400mA flexC Ip EXC
- Correlated colour temperature*: 4000 Kelvin
- Chromaticity tolerance (initial MacAdam): 2
- Rated median useful life*:
 - L80 100000 h at 25 °C
 - L95 75000 h at 25 °C
 - L95 50000 h at 25 °C
- Luminaire input power*: 17.4 W Power factor = 0.87
- Maintenance category CIE 97: C - Closed Top Reflector
- Total harmonic distortion (THD): 29.30 %

This product contains a light source of energy efficiency class C.

All values marked with an * are rated values. Connected electrical load and luminous flux are subject to an initial tolerance of +/- 10%, the most similar colour temperature is subject to an initial tolerance of +/- 150K. Unless stated otherwise, the values apply to an ambient temperature of 25°C. The level of luminous flux reduces over the life cycle due to technological reasons. The failure of up to 1 LED points causes no functional impairment and is therefore no reason for complaint.