



ELVOX Door entry: Axial-Doppeltaste Pixel

41112

ELVOX Door entry / Universalkomponenten / Pixel

Axial-Doppeltaste Pixel

Doppelte Axialtaste

Product Status

3 - Aktiv

Minimum order quantity

1 NR

Sheets, Manuals, Documentation

- [Mehrsprachig-Gebrauchsinformation \(5969 kb\)](#)
- [Beschriftungsvorlage für Namensschilder \(2191 kb\)](#)

Video

- [Video-Türstation Pixel](#)
- [Retrofit mit bereits installierten](#)
- [Nach der Installation](#)
- [Interaktion mit der TAB Free](#)
- [Installation und Konfiguration](#)



Drawings

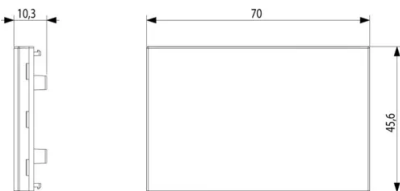

Space view

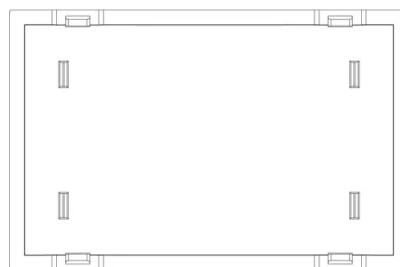

Backside view

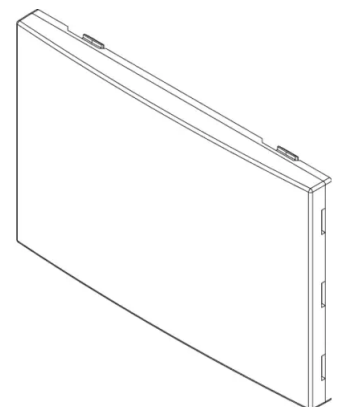

3D View



Technical data

- **Gruppe:** Kommunikationstechnik/Komponenten und Sy
- **Klasse:** Montageelement für Hausstation
- **Material:** Other

- **Colour:** White
- **Height:** 45,60 mm
- **Depth:** 10,30 mm

Certifications

- 00. CE-Kennzeichnung - EU

Packaging



8 013406 271488
Code 8013406271488
Quantity 1 NR
Dim. 7x4,6x1,3 [cm]
Weight 14 [g]



8 013406 271495
Code 8013406271495
Quantity 10 NR
Dim. 12,8x8,5x4,5 [cm]
Weight 167 [g]



8 013406 271976
Code 8013406271976
Quantity 120 NR
Dim. 28x26,5x11,5 [cm]
Weight 2.209 [g]

Legal

Vimar reserves the right to change at any time and without notice the characteristics of the products reported. Installation should be carried out by qualified staff in compliance with the current regulations regarding the installation of electrical equipment in the country where the products are installed. For the terms of use of the information on the product info sheet see [Nutzungsbedingungen](#).