

Type T3C 250M-4

Cod. R2500455,0B3B5G0000T

Mounting position

IM	B3
IM	1001

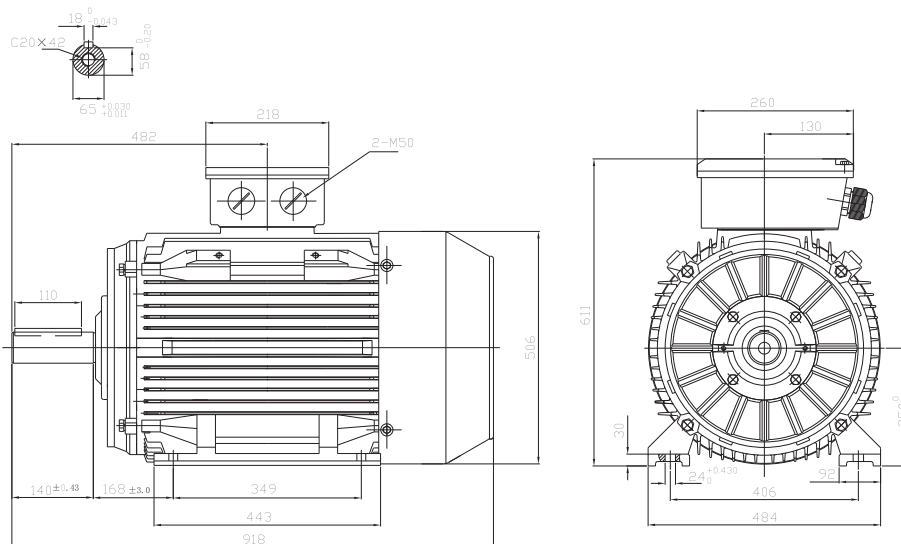

Electrical data			
Rated motor power	55		Kw
Rated motor speed	1480		min ⁻¹ 50Hz
	1780		min ⁻¹ 60Hz
Rated motor frequency	50		Hz
Rated motor voltage(+/-10%)	400		VΔ/50Hz
	690		VY/50Hz
	480		VΔ/60Hz
	830		VY/60Hz
Rated motor torque	354.87		Nm (Mn)
Rated motor current	95.36	VΔ/50Hz	A (In)
	55.12	VY/50Hz	A (In)
Starting motor current	7.4		xIn
Starting motor torque	2.4		xMn
Breakdown motor torque	2.7		xMn
Starting			D.O.L.
Efficiency class	IE3		
Efficiency	50Hz	60Hz	
	94.6	95.7	100% load
	95.2	96.4	75% load
	94.5	94.9	50% load
Power factor cosφ	0.88	0.88	100% load

General data			
Frame size	250		
Mounting	B3		
Weight	479.36		Kg
Casing material	Cast iron		
Protection	IP	55	
Insulation class/Temperature rise	F	/	B
Tropicalization	Yes		
Vibration class	N		
Duty	S1		
Direction of rotation	Bidirectional		
Method of cooling	IC	411	
Cable entry	2-M50x1,5+1M16x1,5		
Standards	IEC/DIN/ISO/VDE/EN		
Execute at Standard	IEC 60034-1		
Feet removable	Yes		
Paintwork	RAL	7024	dark grey
Thermal protections	PTC 150°C		Standard

Site conditions	
Ambient temperature	from -20°C to +40°C
Altitude above sea level	1000 m

Mechanical data					
Noise level	LpA	70	dB(A)	Bearing DE side	6314-C3
	LwA	80	dB(A)	Bearing NDE side	6314-C3
Moment of inertia	0.76504		Kgm ²	Average bearing lifetime	40000 h
Bearings type			NSK	Relubrication interval L1 DE bearing	11500 h
Lubricants for bearings	See installation and maintenance manual page 12			Relubrication interval L1 NDE bearing	11500 h
				Compensation ring	NDE SIDE