

Type T3A 132S2-2

Cod. R1320207,5B5B5A0TAMT

Mounting position

IM	B5
IM	3001

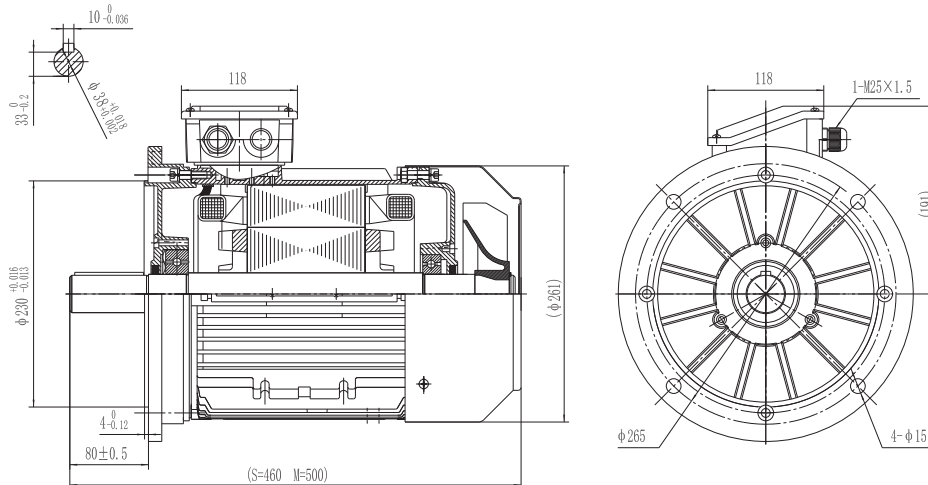

Electrical data			
Rated motor power	7.5		Kw
Rated motor speed	2910		min ⁻¹ 50Hz
	3495		min ⁻¹ 60Hz
Rated motor frequency	50		Hz
Rated motor voltage(+/-10%)	400		VΔ/50Hz
	690		VY/50Hz
	480		VΔ/60Hz
	830		VY/60Hz
Rated motor torque	24.61		Nm (Mn)
Rated motor current	13.65	VΔ/50Hz	A (In)
	7.89	VY/50Hz	A (In)
Starting motor current	7.9		xIn
Starting motor torque	2.7		xMn
Breakdown motor torque	2.8		xMn
Starting			D.O.L.
Efficiency class	IE3		
Efficiency	50Hz	60Hz	
	91.1	90.3	100% load
	91.2	89.7	75% load
	90.1	88.9	50% load
Power factor cosφ	0.88	0.88	100% load

General data			
Frame size	132		
Mounting	B5		
Weight	61.8		Kg
Casing material	Aluminum		
Protection	IP	55	
Insulation class/Temperature rise	F	/	B
Tropicalization	Yes		
Vibration class	N		
Duty	S1		
Direction of rotation	Bidirectional		
Method of cooling	IC	411	
Cable entry	2-M25x1,5		
Standards	IEC/DIN/ISO/VDE/EN		
Execute at Standard	IEC 60034-1		
Feet removable	Yes		
Paintwork	RAL	7024	dark grey
Thermal protections	PTC 150°C		Standard

Site conditions	
Ambient temperature	from -20°C to +40°C
Altitude above sea level	1000 m

Mechanical data						
Noise level	LpA	69	dB(A)	Bearing DE side	6308-2RS-C3	
	LwA	78	dB(A)	Bearing NDE side	6208-2RS-C3	
Moment of inertia	0.0167		Kgm ²	Average bearing lifetime	40000 h	
Bearings type			NSK	Relubrication interval L1 DE bearing	life h	
Lubricants for bearings	See installation and maintenance manual page 12			Relubrication interval L1 NDE bearing	life h	
				Compensation ring		NDE SIDE standard

NO LOAD

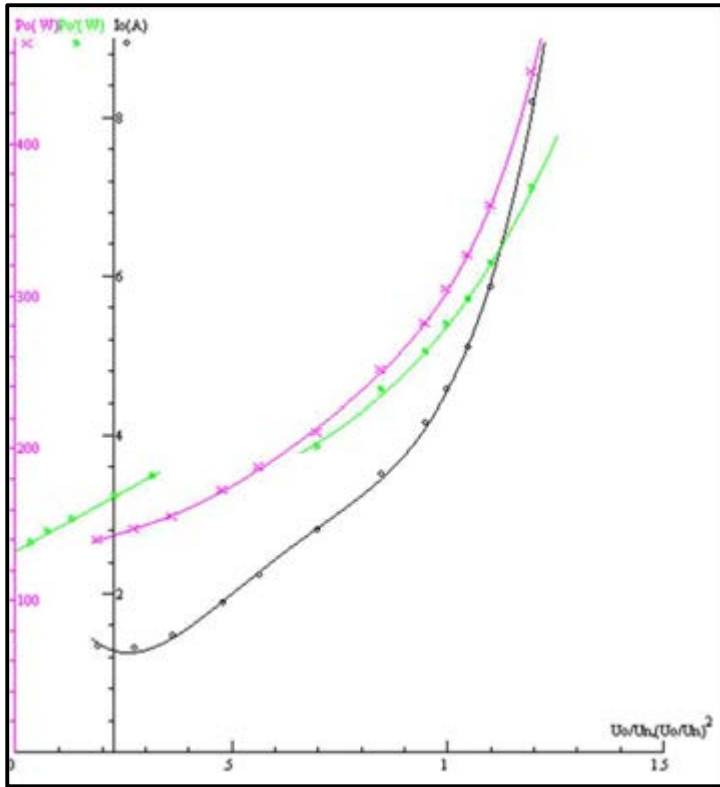

LOCKED ROTOR

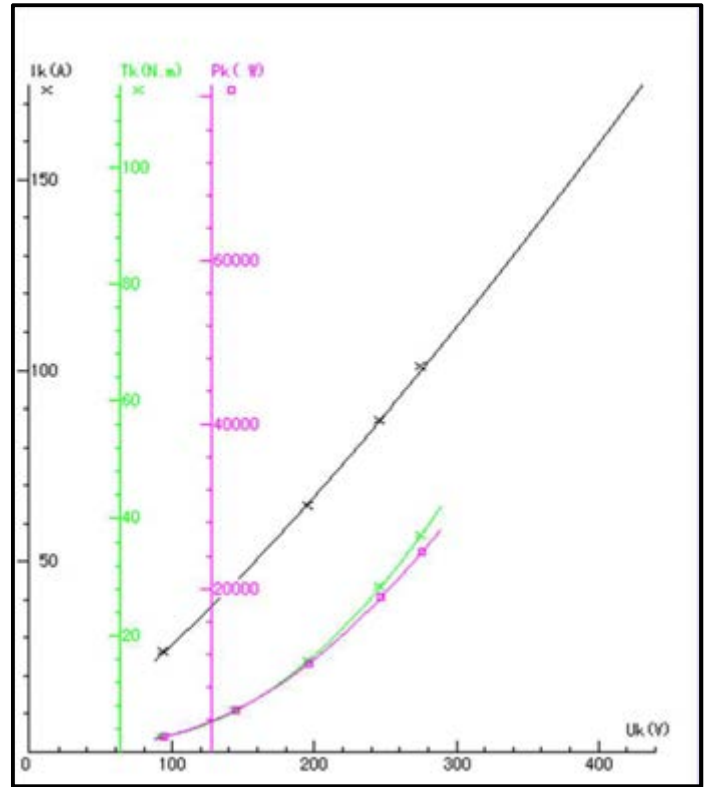

LOAD

